

HX35Az HX40A HX48Az

COMPACT EXCAVATOR



Engine Output
24.8 hp (18.5 kW) – 39.0 hp (29.1 kW)

Bucket Capacity
0.11 - 0.15 m³

Operating Weight
3880 – 5030 kg

 **HD HYUNDAI**

BREAKING STANDARDS IN PRODUCTIVITY & PERFORMANCE

Introducing three new HX A-Series compact tracked excavators, the HX35A Z and HX48A Z with zero tailswing and the HX40A with conventional, minimal tail overhang. All three machines benefit from brand-new Stage V engines, delivering from 18.5 to 29.1 kW (24.8 - 39.0 hp) gross power. The machines are also available with quick coupler fitting, for easy attachment changes to increase your productivity.

Greater efficiency

The new engine meets EU Stage V emission regulations without needing special exhaust after-treatment devices, resulting in reduced maintenance costs.

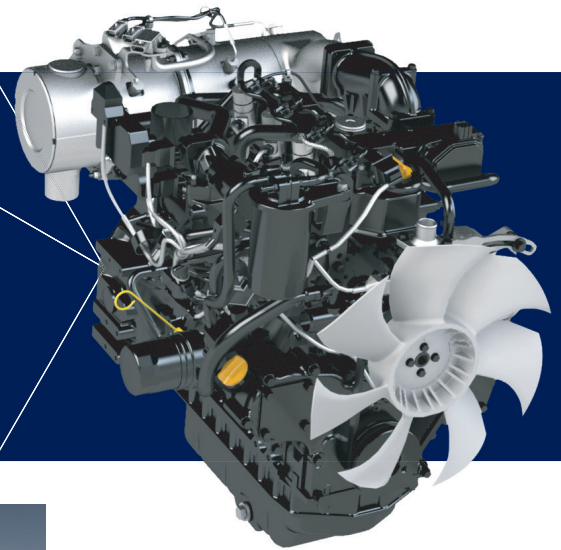

◀ 2 Way Auxiliary Piping

All models are equipped with 2-way auxiliary piping as standard. Single or double acting mode can be selected by the operator.

Load sensing system

The HX40A and the HX48AZ are equipped with a hydraulic load sensing system increasing fuel efficiency when idling and increasing power when it's needed for heavy lifting and other work.

Quick Coupler piping **OPTION**

The HX-A mini excavators are available with an optional factory-fitted hydraulic line to operate any hydraulic quick coupler. This allows quick changes of attachments without having to leave the cabin.



Compact power

The HX40A is a conventional tailswing machine with minimal overhang and offers more digging and lifting power. It is available with a cabin or an optional canopy version.

Heavy counterweight **OPTION**

The HX35A Z can be fitted with an additional counterweight for increased stability when handling heavy loads.

Dozer blade float function

The blade automatically floats above the surface to allow for smooth back grading. This provides the operator with greater versatility and speed, as the excavator can clear and grade in one fluid motion.

4-way dozer blade **OPTION**

The new optional 4-way angle dozer blade offers a great solution for grading material, back-filling of trenches or snow removal. The blade angle is easily adjusted from the cabin by fingertip control, allowing for swift and precise operation. Levelling has never been so convenient.

The angle blade offers more flexibility in your daily work by tilting sideways on top of the standard movements.



True Zero-tail

The HX35A Z and HX48A Z are both true zero tailswing excavators with no rear overhang, allowing them to rotate freely within their own footprint. This enhances manoeuvrability and safety, while minimising the risk of damage to surrounding structures.

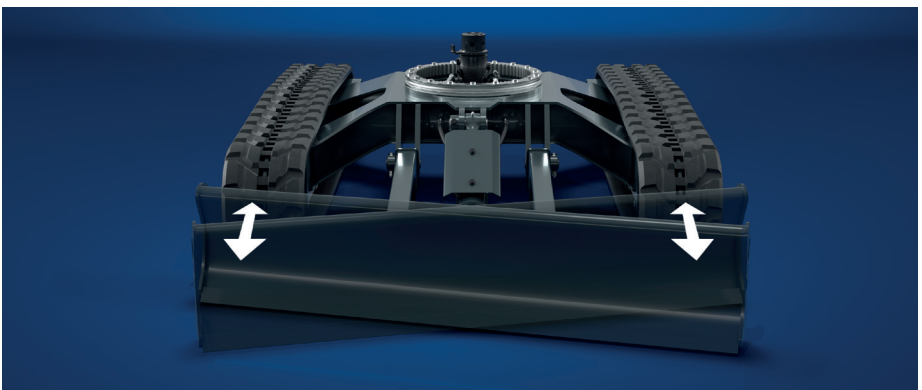
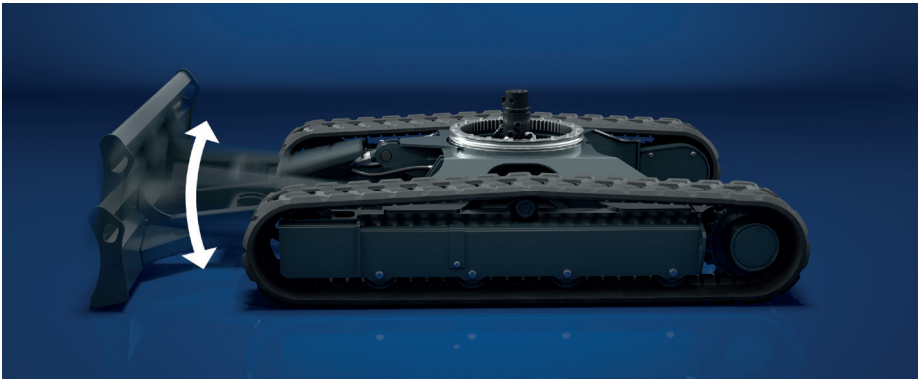

BREAKING STANDARDS IN COMFORT & EASE OF USE

Our new cabin has been designed with operator comfort and convenience in mind. Optimised ergonomics and advanced features allow you to work with greater ease and efficiency. With its spacious interior and high-visibility design, our new cabin offers an unparalleled level of comfort and safety, ensuring that you can work for extended periods without fatigue or discomfort.

◀ New 5-inch digital display

The HX-A mini excavators have a new 5-inch LCD full-colour display monitor, allowing you to easily control excavator settings and quickly access critical functions and daily operations. The monitor is also IP68 waterproof, especially important if working in a canopy model.

Adjustable auxiliary pressure monitor

You can adjust the hydraulic attachment flow using the digital display on all 3 models as standard, for improved speed and ease-of-use.

Auto-shift travel speed

This automated feature allows for seamless transitioning between high and low travel speeds, allowing the operator to focus on the task at hand while the machine takes care of speed and traction adjustments.

◀ Excellent visibility

Experience a whole new level of visibility with our latest cabin design. Enhanced visibility provides you with a wider and more expansive field of view, giving you a clear and unobstructed view of your surroundings.





Proportional finger tip control **A**

Use the dozer blade lever with fingertip control to define the perfect driving speed when grading.

Proportional joysticks **B**

The proportional joysticks (option on HX35A Z) as standard will greatly improve the operability of your machine and your attachments.



Modern audio system

Relax with convenient modern functions like the MP3 radio with added USB ports and enjoy hands free calls.

Canopy version **OPTION**

All three models can be supplied in canopy versions to improve your visibility even more.

BREAKING STANDARDS IN SAFETY

HD Hyundai excavators have some of the highest safety standards in the industry, offering state-of-the-art features, some of which are unique in the industry. Our philosophy is to care for the machine, operator and the environment.

▶ Auto Safety Lock

The auto safety lock prevents unintentional ignition and machine movement. When the safety lever is locked, the engine cannot be started and the system will not engage.

Overload warning

Available as standard, this warning device gives an audible and visible alarm when there's too much weight being lifted, to alert the operator.

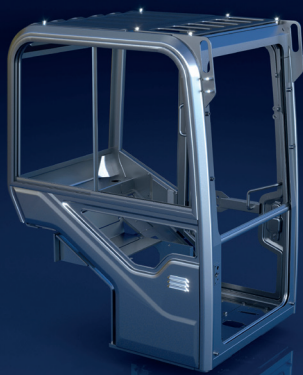

◀ Cabin structure

The HX A-Series cabin structure uses integrally welded low-stress, high strength steel to meet ROPS, TOPS and FOG certification.

- **ROPS:** Roll-Over Protective Structures ISO12117-2
- **TOPS:** Tip-Over Protective Structures EN13531
- **FOG:** Falling Object Guard, ISO10262 Level2

▶ Anti-theft system

The system includes a password-protected ignition key, to prevent the engine from starting without the correct key. Additionally, there is an optional GPS tracker (Hi-Mate) that allows you to quickly locate the machine in case of theft.

Rear view camera **OPTION**

The HX40A and HX48AZ have the option to include a rear-view camera, allowing a clear view of all your surroundings and improving overall safety.

Travel Alarm
Emergency Engine Stop Switch

Work light & beacon lamp **OPTION**

Safety Belt **NEW**
Warning Alarm



► Safety valves

The safety valve on the boom, arm and dozer blade cylinder ensures safe digging or lifting with the blade down, even in case of a sudden pressure drop.

► Boom, arm & bucket cylinder guards

We have added new cylinder guards as standard to the boom, arm, and bucket to provide increased protection. They effectively shield the hydraulic cylinders from damage caused by debris and other external factors, reducing the risk of downtime and costly repairs.



TECHNOLOGY
TO KEEP YOU
SAFE



BREAKING STANDARDS IN SERVICEABILITY & TELEMATICS

The true value of HX A-Series machines lies in their durability with robust structures and attachments, as well as easy access for maintenance and long service intervals. Cutting-edge telematics allows owners and operators to access vital machine information onboard and remotely.

► Designed for easy maintenance

All three models have a tiltable cabin and a new cowl layout, to maximise uptime and keep service work to a minimum.



QUICK
SERVICING FOR
MAXIMUM
UPTIME



HD HYUNDAI

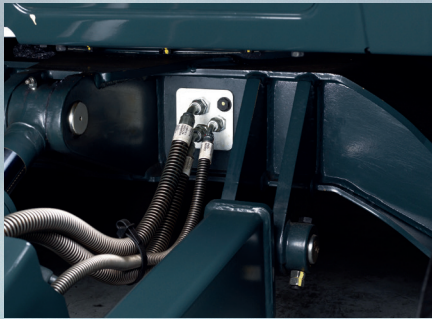

Dozer cylinder maintenance

Chassis connections allow for the easy replacement of hoses, ensuring easier servicing and maintenance.

Improved attachment durability

Our upgraded attachments are designed to withstand the toughest work environments, featuring reinforced steel components and advanced welding techniques to ensure maximum strength and longevity.

Hi MATE

It's convenient, easy and valuable. Hi MATE, Hyundai's remote management system, utilises GPS satellite technology to provide customers with the highest level of service and product support available.

Increase productivity

By providing information such as service hours, and idle time, Hi MATE saves you money and improves productivity. Service alerts enable better maintenance planning.

Monitor your machines

Hi MATE's real-time location information allows convenient monitoring of your equipment via the Hi MATE website or mobile app.

Improve Security

Protect your equipment from theft or unauthorised usage. Hi MATE's geofencing alerts notify you automatically when a machine leaves a predetermined zone.

Mobile fleet app

Our new mobile app provides all the information you need to run your equipment more efficiently and economically. It has been optimised for fleet management, providing health insights based on telematic technology to keep your machines working at maximum performance.



Keeping you covered

HD Hyundai Genuine Parts and Accessories are designed to keep your machine running at optimum performance, with 24-hour delivery across our dealer network. HD Hyundai Standard and Extended Warranty Programmes provide peace of mind and give you full control over your operating costs.



HX35A Z / HX40A / HX48A Z SPECIFICATIONS

SPECIFICATIONS		HX35A Z	HX40A	HX48A Z
Model		HX35A Z	HX40A	HX48A Z
Operating weight	kg	3880	4390	5030

ENGINE		HX35A Z	HX40A	HX48A Z
Manufacturer		Kubota	Yanmar	Yanmar
Model		D1703	4TNV88C	4TNV88C
Type		Vertical, Water-Cooled 4-cycle DI Diesel engine	4 cycle, Inline, Water-Cooled Diesel engine	4 cycle, Inline, Water-Cooled Diesel engine
Emission standard		Stage V	Stage V	Stage V
Gross	hp (kW)	24.8 (18.5)	39.0 (29.1)	39.0 (29.1)
Net	hp (kW)	24.2 (17.8)	38.2 (28.1)	38.2 (28.1)
Peak torque	Nm	97.4	144.9	144.9
No. of cylinders		3	4	4
Bore x Stroke		mm 87.0 x 92.4	88 x 90	88 x 90
Displacement		cc 1647	2190	2190

HYDRAULIC SYSTEM		HX35A Z	HX40A	HX48A Z
Pump type		Variable displacement tandem axis piston pumps	Load sensing system	Load sensing system
Max. pressure	kgf/cm ²	230	254	254
Max. flow rate	l/min	2 x 37.4 + 23.1	99	121
Aux. flow rate (2way)	l/min	60.5	80	80
Aux. flow rate (4way)	l/min	60.5	40	40
Fuel tank capacity		l 46.8	66.8	66.8
Hydraulic capacity (tank/system)		l 36/ 63	44 / 78	44 / 83

PERFORMANCE		HX35A Z	HX40A	HX48A Z
Bucket breakout force (ISO)	kN (kgf)	32 (3281)	44 (4461)	37 (3814)
Arm tearout force (ISO)	kN (kgf)	20 (2025)	20 (2060)	24 (2431)
Travel speed (high/low)	km/h	2.6/4.4	3.3/4.9	2.8/4.4
Traction force	kg	3039	3013	4650
Swing speed	rpm	9.4	9.9	10.1

KEY SPECIFICATIONS		HX35A Z	HX40A	HX48A Z
Boom length	mm	2400	2600	2800
Arm length	mm	1300/ 1600	1600	1400
Bucket capacity, std. CECE	m ³	0.09	0.09	0.13
Boom swing angle left/right	degree	75° / 50°	75° / 55°	70° / 60°
Rubber track width	mm	300	350	400
Ground pressure	kgf/cm ²	0.36	0.34	0.34
Sound level				
Exterior sound level (2000/14/EC - ISO 6395:2008) Lwa	dB(A)	93	95	95
Interior sound level (ISO 6396:2008) Lpa	dB(A)	71.5	71.5	71.4
Air conditioning	The air conditioning system contains fluorinated greenhouse gas refrigerant R134a (Global Warming Potential = 1430). The system contains 0.70 kg of refrigerant representing a CO ₂ equivalent of 1.00 metric tonnes.			

* All equipment dimension is based on cabin, standard boom/arm and counterweight.

HX35A Z / HX40A / HX48A Z

DIMENSIONS & WORKING RANGE

MACHINE DIMENSIONS

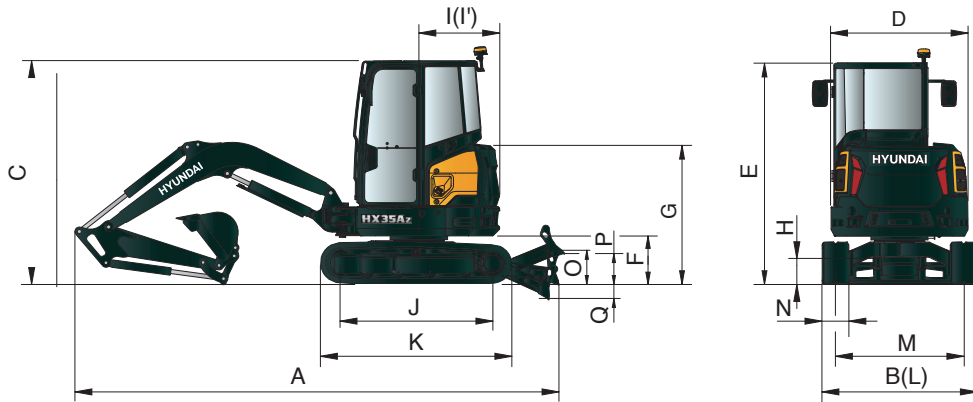

Unit: mm

	HX35A Z	HX40A	HX48A Z
A Overall length	4783	5425	5493
B Overall width	1740	1740	2000
C Overall height	2505	2525	2580
D Overall width of upperstructure	1540	1700	1850
E Overall height of canopy	2505	2525	2580
F Ground clearance of counterweight	525	555	608
G Overall height of engine hood	1545	1550	1605
H Minimum ground clearance	167	185	215
I Rear-end distance	900	1300	1000

	HX35A Z	HX40A	HX48A Z
J Distance between tumbler	1690	1720	2000
K Undercarriage length	2128	2185	2214
M Track gauge	1440	1390	1600
N Track width	300	350	400
O Height of blade	371	380	350
P Ground clearance of blade up	383	400	410
Q Depth of blade down	447	480	580

WORKING RANGE

Unit: mm

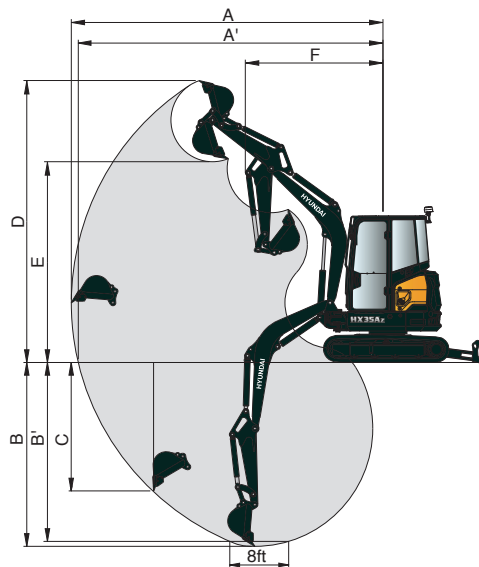

	HX35A Z	HX40A	HX48A Z
Boom length	2400	2600	2800
Arm length	1300	1600	1400
A Max. Digging reach	5,290	5,525	5,990
A' Max. Digging reach on ground	5,170	5,390	5,850
B Max. Digging depth	2,980	3,420	3,500
B' Max. Digging depth (B' level)	2,500	3,010	3,095
C Max. Vertical wall digging depth	2,250	2,620	2,650
D Max. Digging height	4,820	5,360	5,570
E Max. Dumping height	3,415	3,945	3,860
F Min. Swing radius	2,350	2,260	2,540









HX35A Z / HX40A / HX48A Z

LIFTING CAPACITY

 Rating over-front  Rating over-side or 360 degrees











HX35A Z

2.4m boom, 1.3m arm equipped with 300mm rubber track, dozer down position.

Lift-point height m		Lift-point radius						At max. Reach		
		2.0m		3.0m		4.0m		Capacity		Reach m
										
4.0m	kg							*800	*800	3.06
3.5m	kg							*750	610	3.63
3.0m	kg					*730	510	*730	500	4.03
2.5m	kg					*740	510	*730	440	4.30
2.0m	kg			*950	810	*770	500	*730	410	4.48
1.5m	kg			*1120	780	*820	490	*740	390	4.58
1.0m	kg			*1280	750	*870	480	*750	380	4.62
0.5m	kg			*1400	730	*910	470	*760	380	4.58
0.0m	kg	*1350	*1350	*1430	710	*920	460	*770	390	4.47
-0.5m	kg	*1910	1390	*1400	710	*890	460	*780	410	4.28
-1.0m	kg	*2250	1400	*1290	710	*780	460	*780	460	4.01
-1.5m	kg	*1840	1410	*1090	720			*770	540	3.60
-2.0m	kg	*1240	1240	*710	*710			*700	*700	3.01

HX40A

2.6m boom, 1.6m arm, equipped with 350mm rubber tracks, dozer down position

Lift-point height m		Lift-point radius						At max. Reach				
		1.0m		2.0m		3.0m		4.0m		Capacity		Reach m
												
4.0m	kg								*870	850	3.65	
3.0m	kg						*840	730	*790	620	4.38	
2.0m	kg					*1100	*1100	*940	700	*800	530	4.74
1.0m	kg					*1520	1050	*1090	670	*860	500	4.83
0.0m	kg			*1750	*1750	*1770	990	*1200	650	*980	510	4.68
-1.0m	kg	*1720	*1720	*2860	1880	*1750	980	*1150	640	*1030	590	4.25
-2.0m	kg	*2860	*2860	*2250	1920	*1350	1000			*1070	830	3.40

- Lifting capacities are based on ISO 10567.
- Lifting capacity of the HX A-series does not exceed 75% of tipping load with the machine on firm, level ground or 87% of full hydraulic capacity.
- The Lift-point is bucket pivot mounting pin on the arm (without bucket mass).
- (*) indicates load limited by hydraulic capacity.
- Caution: please be aware of the local regulations and instructions for lifting operations.











HX35A Z / HX40A / HX48A Z

LIFTING CAPACITY

 Rating over-front  Rating over-side or 360 degrees

HX48A Z

2.8m boom, 1.4m arm, equipped with 400mm rubber tracks, dozer down position

Lift-point height m										At max. Reach		
		2.0m		3.0m		4.0m		5.0m		Capacity		Reach
												m
4.0m	kg					*870	790			*870	730	4.17
3.0m	kg					*880	790			*810	540	4.84
2.0m	kg			*1380	1220	*1070	750	*950	500	*830	470	5.18
1.0m	kg			*2000	1110	*1300	700	*1030	480	*900	440	5.26
0.0m	kg	*1190	*1190	*2290	1040	*1460	670	*1080	470	*1040	450	5.11
-1.0m	kg	*2370	2140	*2220	1030	*1450	660			*1110	520	4.68
-2.0m	kg	*3080	2200	*1800	1060					*1170	710	3.87

- Lifting capacities are based on ISO 10567.
- Lifting capacity of the HX A-series does not exceed 75% of tipping load with the machine on firm, level ground or 87% of full hydraulic capacity.
- The Lift-point is bucket pivot mounting pin on the arm (without bucket mass).
- (*) indicates load limited by hydraulic capacity.
- Caution: please be aware of the local regulations and instructions for lifting operations.

HX35A Z / HX40A / HX48A Z

STANDARD/OPTIONAL EQUIPMENT

MODEL	HX35A Z	HX40A	HX48A Z
ENGINE			
Mechanical controlled Kubota engine	●		
Electrical controlled Yanmar engine		●	●
Double-element air filter	●	●	●
Auto-idling	●	●	●
Water separator with filter	●	●	●
Electric fuel filler pump		□	□
HYDRAULIC SYSTEM			
Open center hydraulic system	●		
Load-sensing hydraulic system		●	●
Two-speed travel with auto-shift	●	●	●
Dozer blade floating function	●	●	●
Angle dozer blade	□	□	□
Pressure accumulator	●	●	●
Proportional Aux. control	□	●	●
1 way Aux. hydraulic line for breaker	●		
2 way Aux. hydraulic line for grapple	□	●	●
4 way Aux. hydraulic line for rotating	□	□	□
Divert valve for 2 way hydraulic	□	●	●
Adjustable Aux. flow on cluster	●	●	●
CABIN & CANOPY			
Cabin	●	●	●
Canopy	□	□	□
ROPS (Roll-Over Protective Structure)	●	●	●
TOPS (Tip-Over Protective Structure)	●	●	●
FOG (Falling-Object Guard)	□	□	□
Adjustable Mechanical Suspension Seat	●	●	●
Retractable seatbelt with warning alarm	●	●	●
Heating & Air Conditioning	●	●	●

MODEL	HX35A Z	HX40A	HX48A Z
Travel levers with foot pedals	●	●	●
Power-assisted front window	●	●	●
Rear view camera		□	□
Travel alarm	●	●	●
LED beacon lamp	□	□	□
5" Digital cluster with IP68 water & dust proof	●	●	●
Radio with USB	●	●	●
12V power socket	●	●	●
Side & Rear Mirrors	●	●	●
Cup holder	●	●	●
Horn	●	●	●
WORKING EQUIPMENT			
Zero tail swing	●		●
Boom swing function	●	●	●
Long arm option	□		
Quick coupler piping	□	□	□
Additional counter weight option	□		□
Safety valves for Boom/Arm/Dozer blade	●	●	●
Overload warning alarm	●	●	●
Travel & Swing motor with disc brake	●	●	●
1 LED work light on boom	●	●	●
2 LED work lights on cabin	□	□	□
UNDERCARRIAGE			
Rubber track	●	●	●
Steel track	□	□	□
Interchangeability between rubber and steel track	●	●	●
TELEMATICS			
Hyundai telematic system HiMATE	□	□	□

- Standard
- Optional

* Standard and optional equipment may vary. Contact your Hyundai dealer for more information. The machine may vary according to International standards.

* The photos may include attachments and optional equipment that are not available in your area.

* Materials and specifications are subject to change without advance notice.

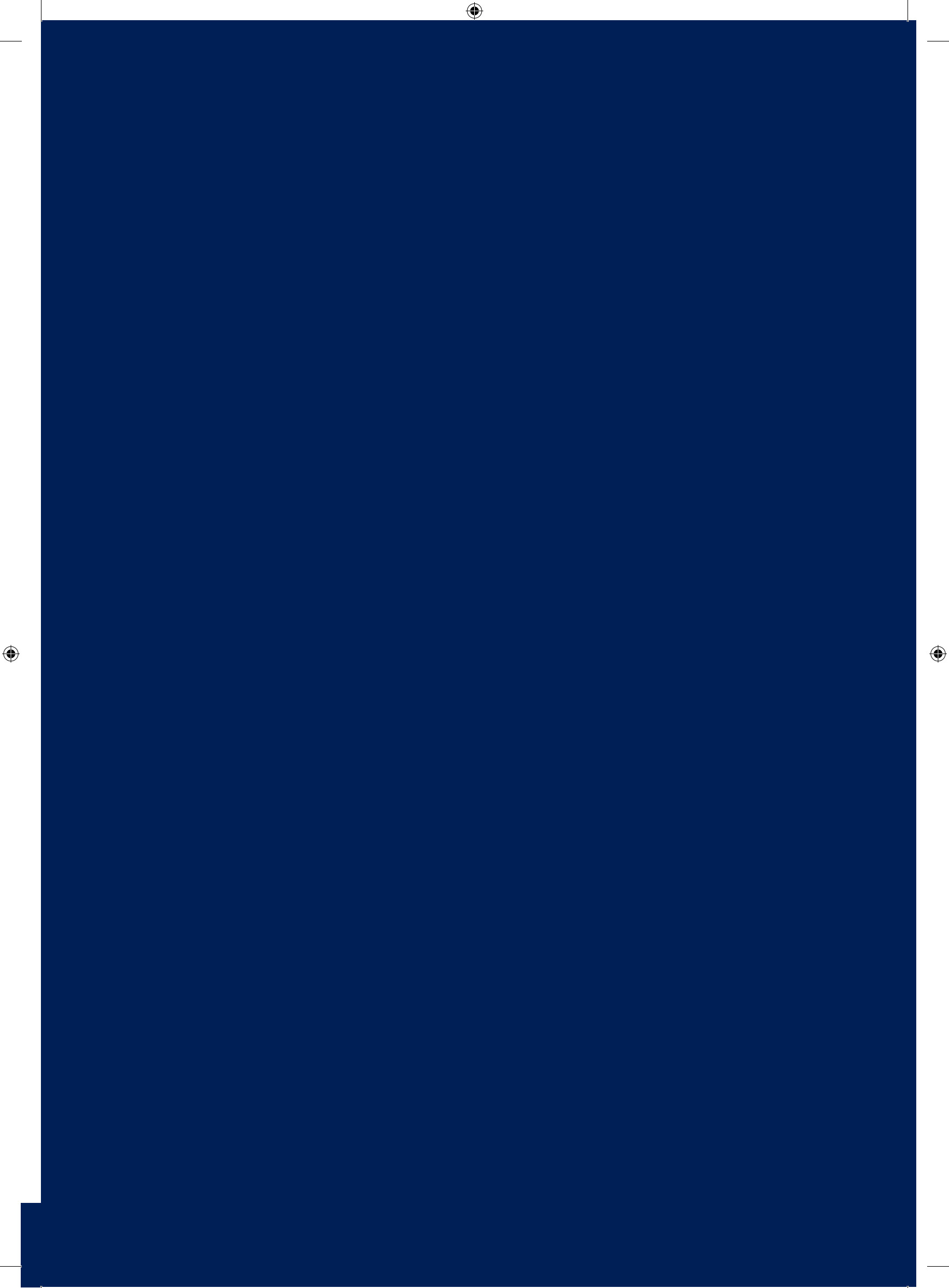



HD Hyundai Construction Equipment Europe nv, Hyundailaan 4,
3980 Tessenderlo, Belgium. Tel: (32) 14-56-2200 Fax: (32) 14-59-3405

Specifications and design are subject to change without notice.
Pictures of HD Hyundai Construction Equipment Europe products may
show other than standard equipment.

READY TO CHANGE YOUR WORLD?

Contact your HD Hyundai dealer.
hyundai-ce.eu/en/dealer-locator

HY-CE-00411. 02/2024. EN. ISSUE 1